

System

500

Supplement

6.0 Parts ordering Information

To obtain service on a component or module please follow these instructions.

1. Using the trouble-shooting charts in section 5, make sure that you have isolated the fault to the component or module.
2. Call your nearest service center or the factory. You will need to give the service representative the following.

**MODEL NUMBER OF YOUR MACHINE
SERIAL NUMBER OF YOUR MACHINE**

If you cannot furnish these numbers it will be extremely difficult for the service department to help you. The serial number and model number are located on a label inside your machine. Service center phone numbers are given on the last page of this manual.

3. Turn off the A.C. power with the master switch in the A.C. Power Box or at the fuse panel of your building. Remove the component from the changer cabinet. (see section 5 for instructions).
4. If the component is to be returned to the factory or service center, pack the component in the original packaging used when the unit was shipped. If the original packaging is not available, use a suitable substitute. Care should be taken to prevent damage to the components from electrostatic discharge and mechanical shipping damage. Multiple compartment stackers require a spacer to prevent forced movement of the carriage during shipping.

NOTE: Please avoid the use of styrofoam "peanuts" when packing. If peanuts are used, the component should be encased in plastic bag to prevent clogging the mechanism.

6.1 Interconnecting Cables

<u>Part Number</u>	<u>Cable Type</u>
4C61700	Stacker Communication Cable
4A00122	Hopper Interrupter
4C61960	Acceptor Power Cable
4C62030	Hopper D.C. Control Cable
4C62000	Keyboard Cable
4C61892	Hopper A.C. Power Cable

6.3 System 500 Note Acceptor Part Numbers

Drawing Ref.	Order #	Description
1 A-Z	04A00108	Upper Track Assembly - U.S.
	04A00200	Upper Track Assembly - Canadian
1 A	02S32716	Upper Track
1 B	02P33973	U.S. Currency Spacer, Right
	02P33971	Canadian Currency Spacer, Right
1 C	02P33974	U.S. Currency Spacer, Left
	02P33972	Canadian Currency Spacer, Left
1 D	02S33230	Track Cover
1 E	04E00104	Upper Track Sensor Board Assembly
1 F	02M33831	Spring Pivot
1 G	02S34043	Toggle Handle
1 H	02S34044	Toggle Pawl
1 J	02S34045	Toggle Pivot
1 K	03R00102	Retaining Ring
1 L	03R00103	Push On Ring
1 N	02Y32660	Idler Spring
1 P	02M36510	Idler Shaft B
1 Q	02P33330	Idler Roller
1 R	02P33341	Creasing Idler Roller
1 S	02M32532	Idler Shaft
1 T	02M35120	Track Axle
1 V	04M00130	Security Gate with Counter Weight
1 X	02S34041	Toggle Arm
1 Y	02S34042	Toggle Link
1 Z	02I00104	Upper Track Seal

Drawing Ref.	Order #	Description
2 A-C	04A00107	Lower Track Assembly
2 C	02S35840	Cell Retainer
3 A-X	04A00132	Chassis Assembly
3 A	02P33182	Detent
3 B	02Y33630	Detent Spring
3 C	02M32520	Chassis Tie Bar
3 D	03R00104	Split Ring
3 E	03R00105	'C' Ring
3 F	02M32553	Single Drive Roller
3 G	02M34220	Idler Gear Axle
3 H	02M32564	Double Drive Roller
3 J	02P33520	Reference Clip
3 K	02M33583	Grooved Drive Roller
3 L	04C34476	System Interconnect Cable
3 M	02P34100	Edge Guide

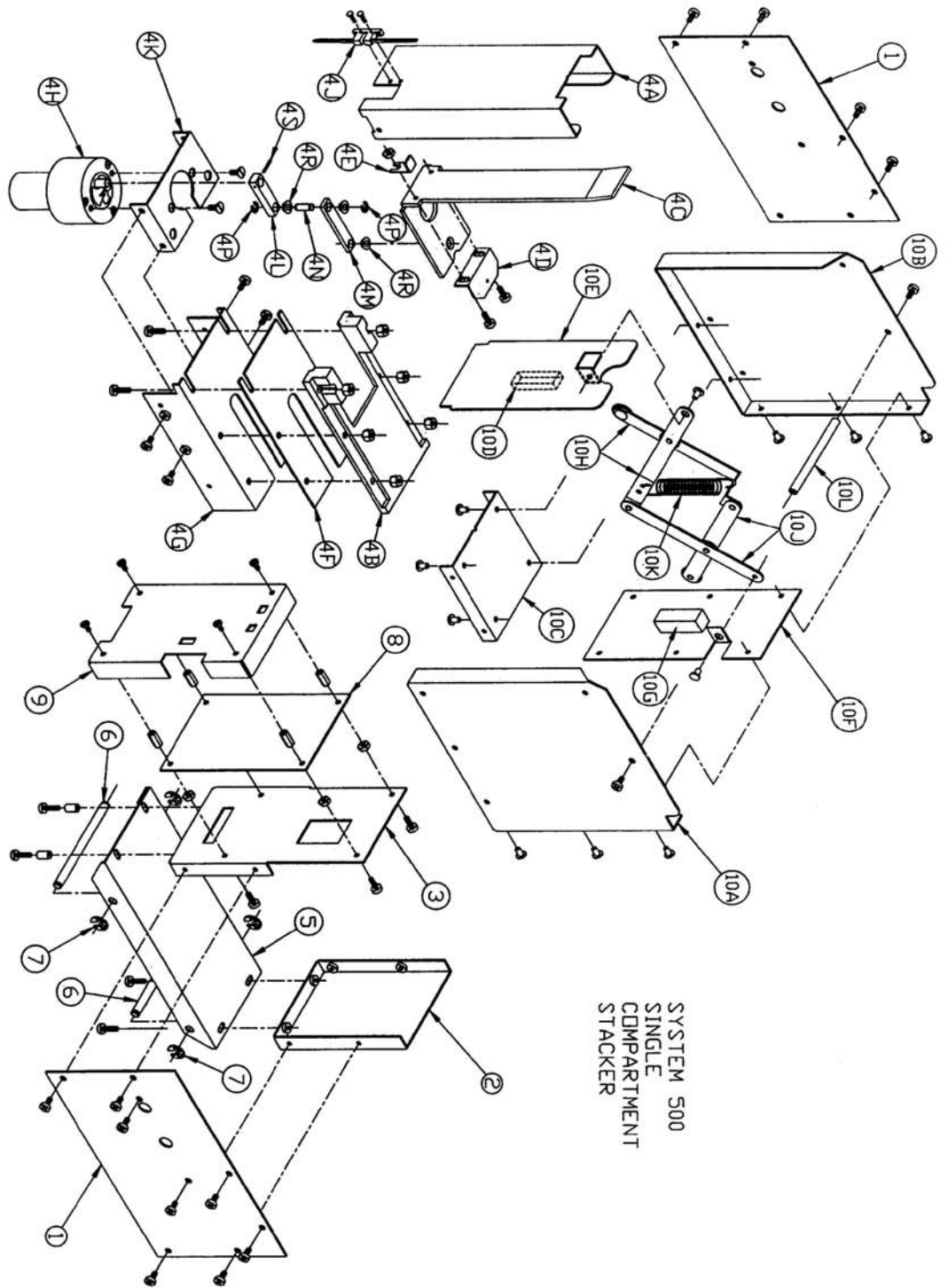

Single Compartment Stacker Drawing

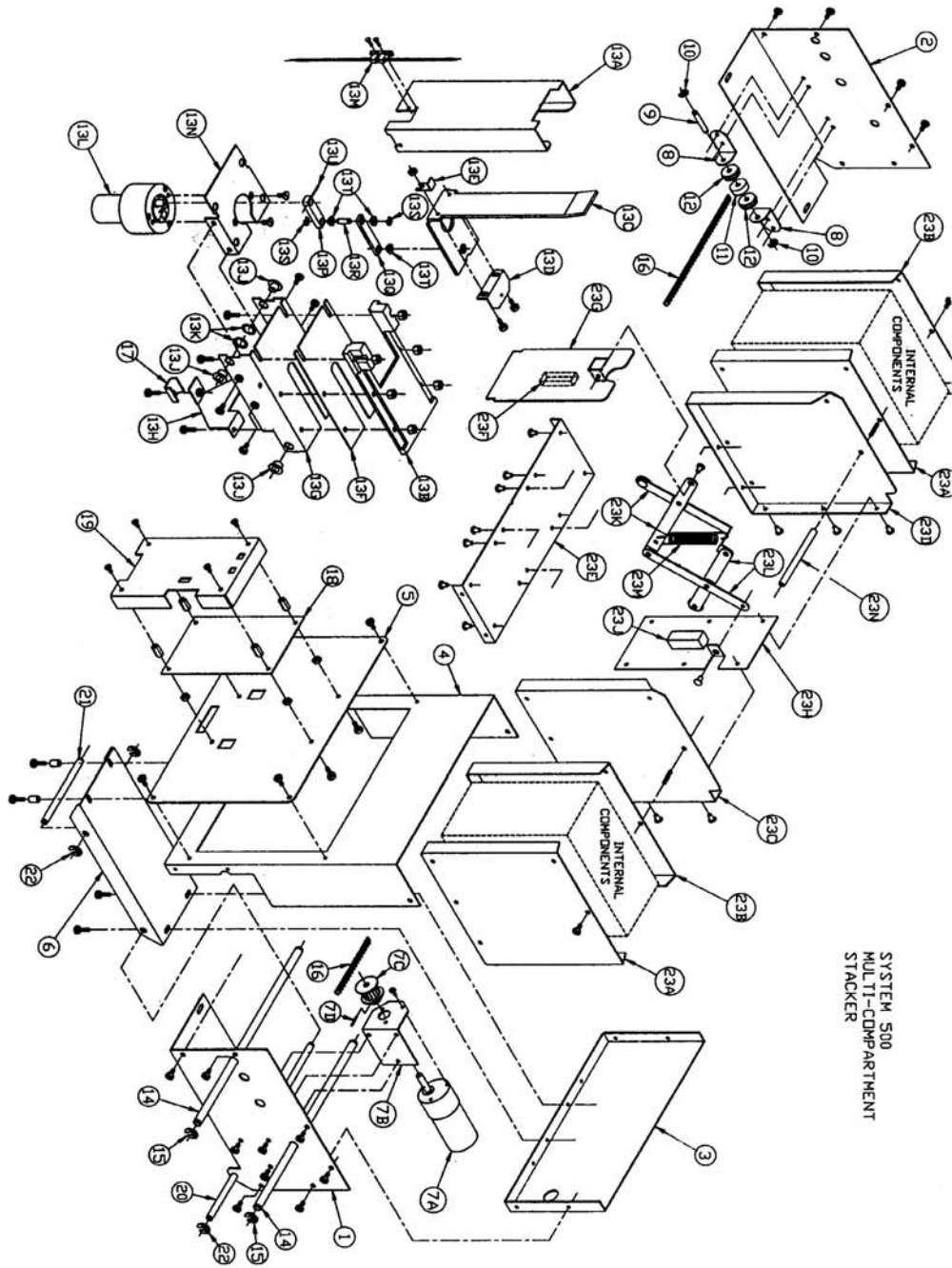

SYSTEM 500
MULTI-COMPARTMENT
STACKER

Multiple Compartments Stacker Drawing

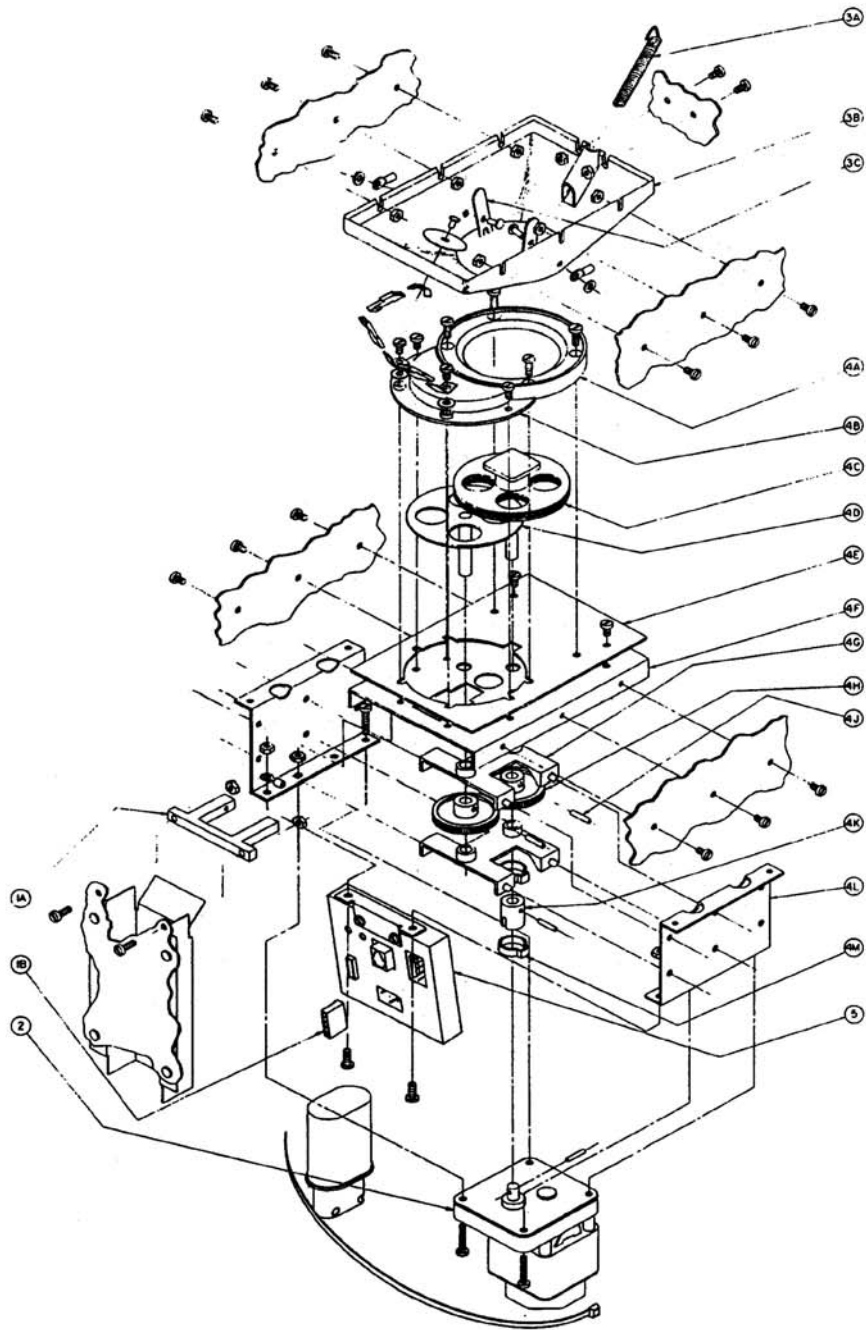

Hopper Assembly Drawing

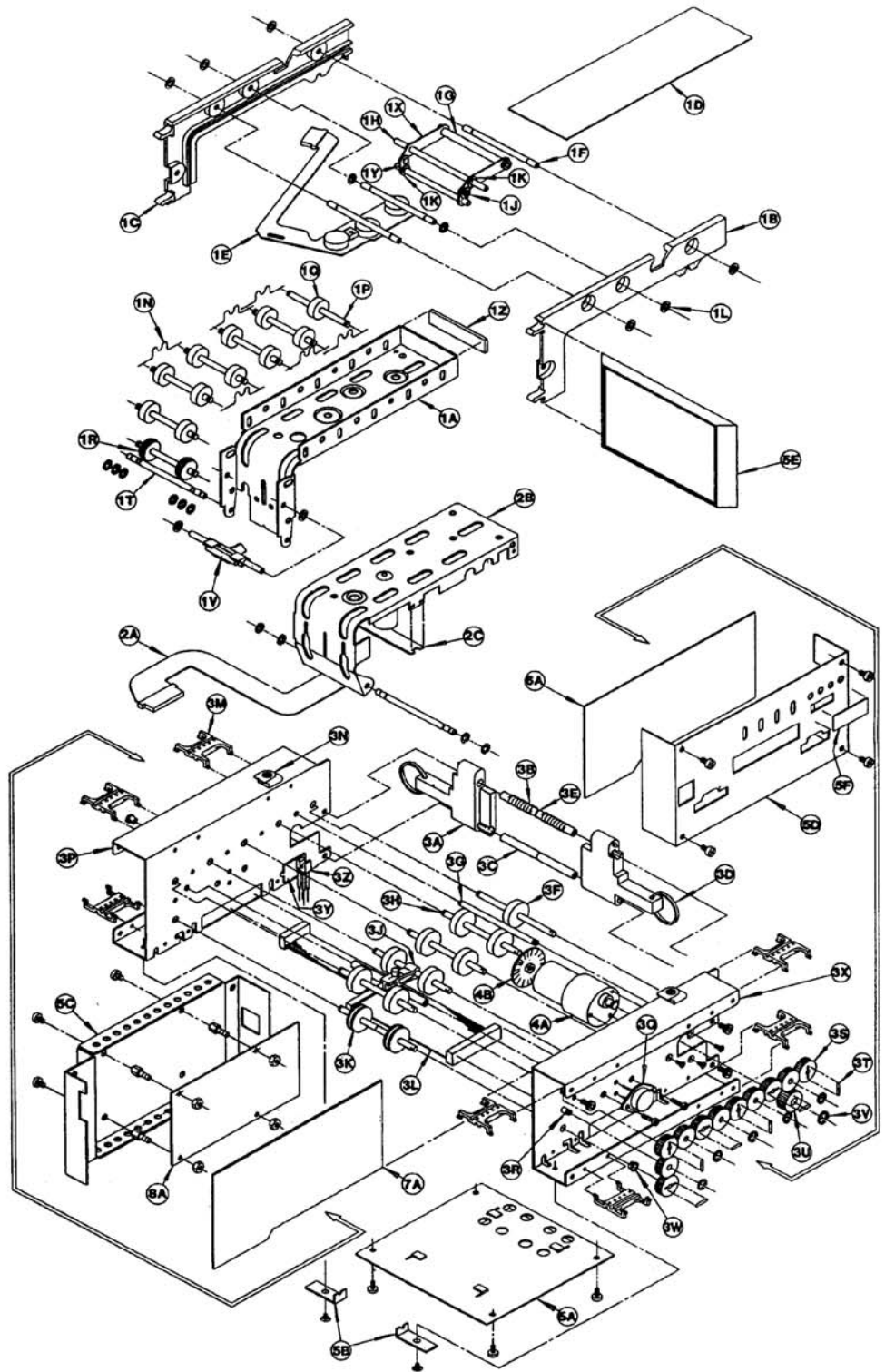

System 500 Note Acceptor Drawing

System 500 Hardware Part Numbers

Order #	Description
03B00104	#8-32 X 3/16 Phillips Head Screw
03B00107	#8-32 X 5/16 Phillips Head Screw
03B00115	#8-32 X 3/8 Phillips Head Screw
03B00111	#8-32 X 3/4 Phillips Head Screw
03B00110	#8-32 X 5/16 Socket Head Cap Screw
03B00105	#8-32 X 3/16 Flat Head Screw
03N00103	#8-32 Hex Nut With Sems Washer
03N00102	#8-32 Hex Nut With Nylock
03B00113	1/4-20 X 3/8 Phillips Head Screw (Hopper)
03S00101	1/4" Nylon Spacer
03S00102	1/4" Metal Spacer
03B00116	1/4 - 20 X 5/8 Pan Head Screw (Stacker)

4.3 Programming the System 500

WARNING

All System 500 changers have been programmed at the factory. A programming keyboard, which allows the machine to be reprogrammed, is standard equipment. Special function keyboards can be ordered. Special keyboards may not allow program access and are not covered in this manual.

4.3.1 The Access Code (See chart in Section 4.9.1)

In order to give the System 500 maximum flexibility, the major bill changer functions may be selected and programmed as instructions to the machine by using the keyboard.

The first instruction to the machine is to enter a code number which will place the machine in a programming mode. This code number is "500" for the System 500. Using the keyboard, press the button "5", and press "0" twice. The display (red letters and numbers at the top of the keyboard) will respond by reading out:

TY-A=XX

NOTE: If the display is reading out a number instead of 00 it means it is already programmed, probably at the factory before the unit was shipped. TY-A=XX will appear on the readout anytime you access the programming mode; computer programmers would call this the default value. To avoid confusion, the expression XX or XXX will be used instead of actual numbers. The exception to this will be where an example demands a definite number.

4.3.2 Assigning A Coin Value to the Hopper. (See chart in Section 4.9.2)

With the display showing TY-A=XX, press the "VALUE" button on the keyboard. The display now reads:

VL-A=XXX

The readout means that the value of the coin assigned to hopper A is that shown in place of the three Xs. If hopper A is a nickel hopper, press the "5" button on the keyboard so that the readout looks like this:

VL-A=005

Each hopper has a designated "value" found on a decal located on the top front of the Hopper.

Of course you could have assigned hopper A any other value, such as 010 for a dime coin or 025 for twenty-five cents. A dollar coin can be assigned as 100--That is why there are three spaces for the value instead of just two. Now push the button marked "HOPPER B". The display will shift to:

TY-C=00
TY-D=00

4.3.4 Programming The Type of Bills Accepted.

Suppose you don't want to accept a twenty dollar bill with your machine. Press the "TWENTY DOLLAR" button on the keyboard. The display will read:

TY-A=20, for example.

Program in zeros in place of 20. Do the same for hoppers B,C,D. Then:

TY-A=00
TY-B=00
TY-C=00
TY-D=00

The note acceptor will no longer accept twenty dollar bills but will reject them instead. The same method is used to lock out any bill denomination. The program:

TN-A=00
TN-B=00
TN-C=00
TN-D=00

will cause the ten dollar bill to be rejected by the note acceptor.

4.3.5 Programming The Accumulate Mode (See chart in Section 4.9.9)

The Accumulate Mode is used to enable the deposit of multiple coins and bills in the changer in exchange for another coin, token or ticket, which the changer dispenses when the correct total deposit amount is reached.

NOTE: You can only program one accumulate value. If you have not already done so, enter the number 500 into the keyboard to place the changer in the programming mode. Press the button on the keyboard marked "ACCUMULATE". The display should read:

AC-A=XX

Enter the number of coins which should be dispensed from A hopper when the accumulate total is reached. If you don't want to dispense from A hopper, leave the number at 00. Press "HOPPER B" button to get:

AC-B=XX

4.3.6 Programming the Quarter (See chart in Section 4.9.8)

CAUTION

It is extremely important that you program the quarter deposit when you have a coin acceptor in your machine. If you do not program the quarter deposit the machine will "steal" quarters.

To accomplish this use the access code 500 to enter the program mode if you are not in the program mode. You will see TY-A=XX again. Then push the button marked "QUARTER"; the display will read

QT-A=XX

Let's assume that your A hopper is a nickel hopper and that your B hopper is a dime hopper. Enter 01 on the keypad. Now press the button marked Hopper B. The display will change to:

QT-B=XX

Enter the number 02. The display will change to:

QT-B=02

The changer is now programmed to return two dimes and a nickel for the quarter which was deposited in the coin panel.

4.3.7 Programming The Stacker (See chart in Section 4.9.10)

If you are not in the programming mode, enter the access code (500). The display will read:

TY-A=XX

Press the button marked "STACKER PROGRAM" on the keyboard. The display will now read:

TY-S=ii2

The readout on the display is telling us that if a twenty dollar bill is accepted it will be stacked in box 2 of the stacker.

NOTE: The numbers for the compartments of a stacker form 3-1-2, corresponding to the position of the compartments of a three compartment stacker when viewed from the rear. In the program above, the twenty would be stacked in the right-most compartment.

Press the button on the keyboard marked "TEN DOLLARS". The display will indicate:

TN-S=ii2

4.4 How To Exit The Program Mode

The program mode is entered by typing in the access code number 500. The machine will not act as a changer in the programming mode so that it is necessary to go back to the changer mode of operation. This is done by pushing the button marked "EXIT" on the keyboard. This will cause the changer to go back into service and leave the program mode. You can regain access at any time by entering "500".

4.5 Reading The Audit (See chart in Section 4.9.11)

To read the audit you must access the audit mode. This is done by pushing the "DISPLAY AUDIT" key on your keyboard. Note that you don't have to gain access with a code number like you do when you program the unit; just push "DISPLAY AUDIT". By repeated pushing of the "DISPLAY AUDIT" button the various readouts will appear.

4.6 Audit Readouts

The following list explains the meaning of the audit readouts:

<u>Money In U.S Coins and Notes:</u>	<u>Display will read:</u>
05--Number of Nickels deposited in the machine.	05-XXXX
10--Number of Dimes deposited in the machine.	10-XXXX
25--Number of Quarters deposited in the machine.	25-XXXX
1C--Number of Dollar Coins deposited in the machine.	1C-XXXX
1B--Number of Dollar Bills deposited in the machine.	1B-XXXX
5B--Number of Five Dollar Bills deposited in the machine.	5B-XXXX
TN--Number of Ten Dollar Bills deposited in the machine.	TN-XXXX
TY--Number of Twenty Dollar Bills deposited in the machine.	TY-XXXX

Money In Canadian Coins And Notes

The readouts through 1C are the same as the U.S. From 1C on they are:

2B--Number of Two Dollar Bills deposited in the machine.	2B-XXXX
5B--Number of Five Dollar Bills deposited in the machine.	5B-XXXX
TN--Number of Ten Dollar Bills deposited in the machine.	TN-XXXX
TY--Number of Twenty Dollar Bills deposited in the machine	TY-XXXX

Money Out

HA--Number of coins paid out of hopper A	HA-XXXX
HB--Number of coins paid out of hopper B	HB-XXXX
HC--Number of coins paid out of hopper C	HC-XXXX
HD--Number of coins paid out of hopper D	HD-XXXX

STEP 1: ACCESS THE PROGRAM MODE

① PUSH	② DISPLAY	③ ENTER
5	005	
0	050	
↓		
0	<u>TY-A=XX</u> ↓ INDICATES YOU ARE IN THE PROGRAM MODE.	

CHOICES

1. STAY IN PROGRAM MODE AND GO TO STEP 2.
2. PUSH AND RESUME CHANGER OPERATION.

STEP 2: VALUE THE HOPPERS

NOTE: YOU MUST BE IN THE PROGRAM MODE.
IF YOU ARE NOT, REPEAT STEP 1.

① PUSH	② DISPLAY	③ ENTER
<p>VALUE</p>	<p>VL-A=XXX</p> <p>NOTE: X MEANS ANY NUMBER.</p>	<p>COIN ASSIGNED TO HOPPER A.</p> <p>- CHOICES - 005 NICKEL 010 DIME 025 QUARTER 100 SBA DOLLAR</p>
<p>HOPPER B</p>	<p>VL-B=XXX</p>	<p>COIN ASSIGNED TO HOPPER B. IF NO HOPPER B, ENTER 000.</p>
<p>HOPPER C</p>	<p>VL-C=XXX</p>	<p>COIN ASSIGNED TO HOPPER C. IF NO HOPPER C, ENTER 000.</p>
<p>HOPPER D</p>	<p>VL-D=XXX</p>	<p>COIN ASSIGNED TO HOPPER D. IF NO HOPPER D, ENTER 000.</p>

CHOICES

1. STAY IN PROGRAM MODE AND GO TO STEP 3.
2. PUSH AND RESUME CHANGER OPERATION.

STEP 3: COINS DISPENSED FROM EACH HOPPER FOR EACH DEPOSIT IN ACCEPTOR/COIN PANEL.

NOTE: YOU MUST BE IN THE PROGRAM MODE.
IF YOU ARE NOT, REPEAT STEP 1.

\$20

① PUSH	② DISPLAY	③ ENTER
<div style="border: 1px solid black; padding: 2px; width: fit-content; margin: 5px auto;">TWENTY DOLLAR</div>	<p>TY-A=XX</p>	<p>NUMBER OF COINS DISPENSED FROM HOPPER A FOR A TWENTY. IF 0 COINS, ENTER 00.</p>
<div style="border: 1px solid black; padding: 2px; width: fit-content; margin: 5px auto;">HOPPER B</div>	<p>TY-B=XX</p>	<p>NUMBER OF COINS DISPENSED FROM HOPPER B FOR A TWENTY. IF 0 COINS, ENTER 00.</p>
<div style="border: 1px solid black; padding: 2px; width: fit-content; margin: 5px auto;">HOPPER C</div>	<p>TY-C=XX</p>	<p>NUMBER OF COINS DISPENSED FROM HOPPER C FOR A TWENTY. IF 0 COINS, ENTER 00.</p>
<div style="border: 1px solid black; padding: 2px; width: fit-content; margin: 5px auto;">HOPPER D</div>	<p>TY-D=XX</p>	<p>NUMBER OF COINS DISPENSED FROM HOPPER D FOR A TWENTY. IF 0 COINS, ENTER 00.</p>
<p>WHENEVER: TY-A=00 TY-B=00 TY-C=00 TY-D=00</p> <p>THE BILL ACCEPTOR WILL NOT ACCEPT A TWENTY DOLLAR BILL.</p>		

CHOICES

1. STAY IN PROGRAM MODE AND CONTINUE TO PROGRAM.
2. PUSH

EXIT

 AND RESUME CHANGER OPERATION.

STEP 3: COINS DISPENSED FROM EACH HOPPER FOR EACH DEPOSIT IN ACCEPTOR/COIN PANEL.

NOTE: YOU MUST BE IN THE PROGRAM MODE.
IF YOU ARE NOT, REPEAT STEP 1.

\$10

① PUSH	② DISPLAY	③ ENTER
<div style="border: 1px solid black; padding: 5px; width: fit-content; margin: 0 auto;">TEN DOLLAR</div>	<p>TN-A=XX</p>	<p>NUMBER OF COINS DISPENSED FROM HOPPER A FOR A TEN. IF 0 COINS, ENTER 00.</p>
<div style="border: 1px solid black; padding: 5px; width: fit-content; margin: 0 auto;">HOPPER B</div>	<p>TN-B=XX</p>	<p>NUMBER OF COINS DISPENSED FROM HOPPER B FOR A TEN. IF 0 COINS, ENTER 00.</p>
<div style="border: 1px solid black; padding: 5px; width: fit-content; margin: 0 auto;">HOPPER C</div>	<p>TN-C=XX</p>	<p>NUMBER OF COINS DISPENSED FROM HOPPER C FOR A TEN. IF 0 COINS, ENTER 00.</p>
<div style="border: 1px solid black; padding: 5px; width: fit-content; margin: 0 auto;">HOPPER D</div>	<p>TN-D=XX</p>	<p>NUMBER OF COINS DISPENSED FROM HOPPER D FOR A TEN. IF 0 COINS, ENTER 00.</p>
<p>WHENEVER: TN-A=00 TN-B=00 TN-C=00 TN-D=00</p>		
<p>THE BILL ACCEPTOR WILL NOT ACCEPT A TEN DOLLAR BILL.</p>		

CHOICES

1. STAY IN PROGRAM MODE AND CONTINUE TO PROGRAM.
2. PUSH EXIT AND RESUME CHANGER OPERATION.

STEP 3: COINS DISPENSED FROM EACH HOPPER FOR EACH DEPOSIT IN ACCEPTOR/COIN PANEL.

NOTE: YOU MUST BE IN THE PROGRAM MODE.
IF YOU ARE NOT, REPEAT STEP 1.

\$5

① PUSH	② DISPLAY	③ ENTER
FIVE DOLLAR	$5D-A=XX$	NUMBER OF COINS DISPENSED FROM HOPPER A FOR A FIVE. IF 0 COINS, ENTER 00.
HOPPER B	$5D-B=XX$	NUMBER OF COINS DISPENSED FROM HOPPER B FOR A FIVE. IF 0 COINS, ENTER 00.
HOPPER C	$5D-C=XX$	NUMBER OF COINS DISPENSED FROM HOPPER C FOR A FIVE. IF 0 COINS, ENTER 00.
HOPPER D	$5D-D=XX$	NUMBER OF COINS DISPENSED FROM HOPPER D FOR A FIVE. IF 0 COINS, ENTER 00.
<p>WHENEVER: $5D-A=00$ $5D-B=00$ $5D-C=00$ $5D-D=00$</p>		
<p>THE BILL ACCEPTOR WILL NOT ACCEPT A FIVE DOLLAR BILL.</p>		

CHOICES

1. STAY IN PROGRAM MODE AND CONTINUE TO PROGRAM.
2. PUSH AND RESUME CHANGER OPERATION.

STEP 3: COINS DISPENSED FROM EACH HOPPER FOR EACH DEPOSIT IN ACCEPTOR/COIN PANEL.

NOTE: YOU MUST BE IN THE PROGRAM MODE.
IF YOU ARE NOT, REPEAT STEP 1.



① PUSH	② DISPLAY	③ ENTER
ONE DOLLAR	DL-A=XX	NUMBER OF COINS DISPENSED FROM HOPPER A FOR A DOLLAR. IF 0 COINS, ENTER 00.
HOPPER B	DL-B=XX	NUMBER OF COINS DISPENSED FROM HOPPER B FOR A DOLLAR. IF 0 COINS, ENTER 00.
HOPPER C	DL-C=XX	NUMBER OF COINS DISPENSED FROM HOPPER C FOR A DOLLAR. IF 0 COINS, ENTER 00.
HOPPER D	DL-D=XX	NUMBER OF COINS DISPENSED FROM HOPPER D FOR A DOLLAR. IF 0 COINS, ENTER 00.
<p>WHENEVER: DL-A=00 DL-B=00 DL-C=00 DL-D=00</p> <p>THE BILL ACCEPTOR WILL NOT ACCEPT A DOLLAR BILL.</p>		

CHOICES

1. STAY IN PROGRAM MODE AND CONTINUE TO PROGRAM.
2. PUSH **EXIT** AND RESUME CHANGER OPERATION.

STEP 4: PROGRAM THE ACCUMULATE MODE

NOTE: YOU MUST BE IN THE PROGRAM MODE.
IF YOU ARE NOT, REPEAT STEP 1.

① PUSH	② DISPLAY	③ ENTER
ACCUM- ULATE	AC-A=XX	GO TO NEXT STEP
↓ VALUE	AC-V=XXX	ENTER THE AMOUNT YOU WANT TO ACCUMULATE TO. FOR EXAMPLE 025, (1 QUARTER).
ACCUM- ULATE	AC-A=XX	ENTER NUMBER OF COINS DISPENSED FROM HOPPER A. IF 0 COINS, ENTER 00.
HOPPER B	AC-B=XX	ENTER NUMBER OF COINS DISPENSED FROM HOPPER B. IF 0 COINS, ENTER 00.
HOPPER C	AC-C=XX	ENTER NUMBER OF COINS DISPENSED FROM HOPPER C. IF 0 COINS, ENTER 00.
HOPPER D	AC-D=XX	ENTER NUMBER OF COINS DISPENSED FROM HOPPER D. IF 0 COINS, ENTER 00.

CHOICES

1. STAY IN PROGRAM MODE AND GO TO STEP 2.
2. PUSH AND RESUME CHANGER OPERATION.

DISPLAY THE AUDIT TOTALS

NOTE: IF THE CLEAR AUDIT BUTTON IS PRESSED WHILE THE AUDIT IS DISPLAYED, ALL AUDIT TOTALS WILL BE SET TO 0.

① PUSH	② DISPLAY	③ INDICATES
<p data-bbox="412 730 532 848">DISPLAY AUDIT</p>	<p data-bbox="639 758 889 810">05=XXXX</p>	<p data-bbox="954 751 1326 821">NUMBER OF NICKELS ACCEPTED</p>
<p data-bbox="412 961 532 1079">DISPLAY AUDIT</p>	<p data-bbox="639 989 889 1041">10=XXXX</p>	<p data-bbox="971 982 1304 1052">NUMBER OF DIMES ACCEPTED</p>
<p data-bbox="391 1184 557 1325">REPEAT FOR ALL 12 AUDIT TOTALS.</p>		<p data-bbox="946 1178 1333 1325">YOU MAY CONTINUE TO PRESS THE DISPLAY AUDIT BUTTON TO VIEW THE TOTALS AGAIN.</p>
<p data-bbox="412 1430 532 1547">EXIT</p>		<p data-bbox="946 1415 1333 1562">YOU MAY PRESS THE EXIT BUTTON AT ANY TIME TO RESUME CHANGER OPERATION.</p>



Standard Service & Repair Center
Factory & Home Office

Standard Change-Makers, Inc.
3130 N. Mitthoeffer Road
Indianapolis, IN 46235
Toll Free: 1-800-968-6955
Phone: 317-899-6966
Fax: 317-899-6977
Web Site: www.standardchange.com

SERIAL No.: _____

MODEL No.: _____

Please write down for reference when contacting Service Center